

SERIES 980

REDESIGNED FOR
LED_s

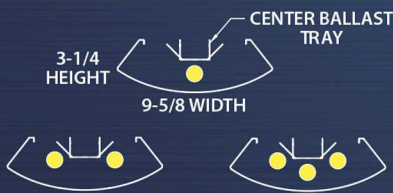

ONE, TWO, OR THREE LED BOARDS



Lamping Options

LED	T8
(1 - 3) 48"	(1 - 3) 32w (48")
(2 - 6) 96"	(2 - 6) 32w (96")

Application

- Open office ambient lighting for virtually glare free and shadow free illumination.
- Indirect/Direct suspended lighting fixture; Indirect is 70% and direct is 30%.
- The direct component is controlled by 3" wide semi-specular aluminum baffles standard or opaque overlay (by others).
- This unit is designed for LED or T8
- Fixture will also accept T8 LED tubes.
- Designed for low brightness illumination for general office or classroom applications where 85 to 90% efficiency is needed. All reflectors necessary for performance are supplied as standard.

Finishes

- Unpainted/unfinished formed steel housings with center slotted openings.
- Customer to source a local powder coating facilities to paint steel housings and die cast aluminum end caps.
- An internal ballast bracket assembly is included with precoated white steel and shipped as an assembly with lamp holder brackets and adjustable ballast mounting.
- Reflectors are enhanced aluminum for maximum efficiency for direct and indirect control.

Features

- Fixtures are shipped with die cast aluminum joiners for structural integrity and suspension continuity.
- Fixtures are designed to mount on exact 4 foot and 8 foot centers. Joiners will accept stems, single cable, "V" cable, and power cords as supplied by others.
- Architectural ends. This die cast aluminum end comes standard with flat styled configuration. Ends are bolted to the die cast joiners for a complete architectural look.
- Housing can be differentiated by specifying perforations on the bottom sides parallel to the center slot, perforations on the top sides, or both. You design the look that you want to achieve.
- Fixture can be modified to accept daylight and/or motion detectors.
- Fixture is 9-5/8" wide by 3-1/4" high.

Optional Features

- The housings are roll formed which allows custom lengths with predictable results. Units could also be used in a wall mounted version. Please contact factory for any optional feature.
- Custom modifications in the physical specification and color are available for this fixture.

Packaging	4'	8'
Bodies	32	32

Specifications subject to change without notice.



Adam Metal Products Company • P.O. Box 450 • Ledgewood, NJ • 07852
Phone: 973.770-1100 • Fax 973.770-1105 • www.adammetal.com



SERIES 980

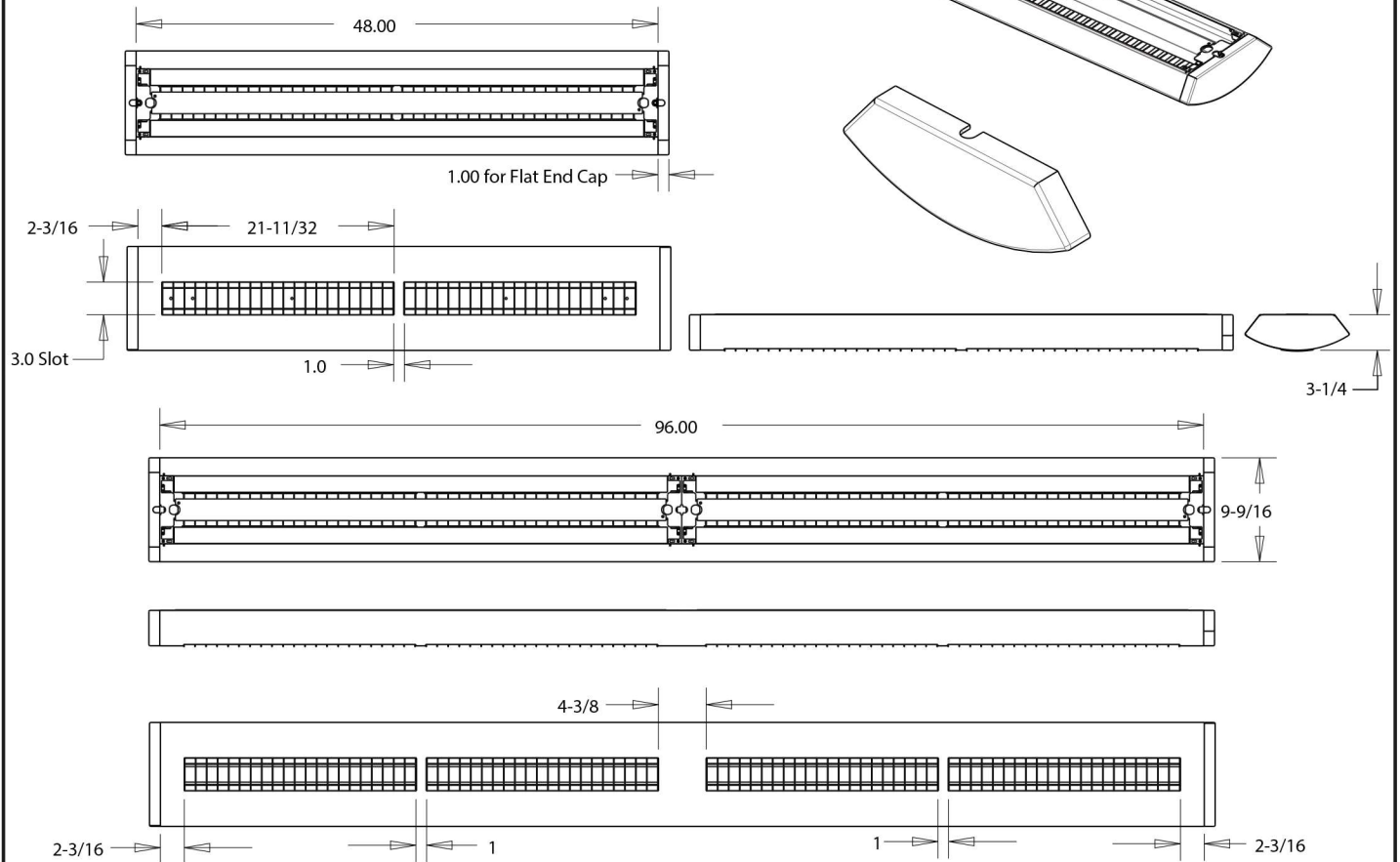
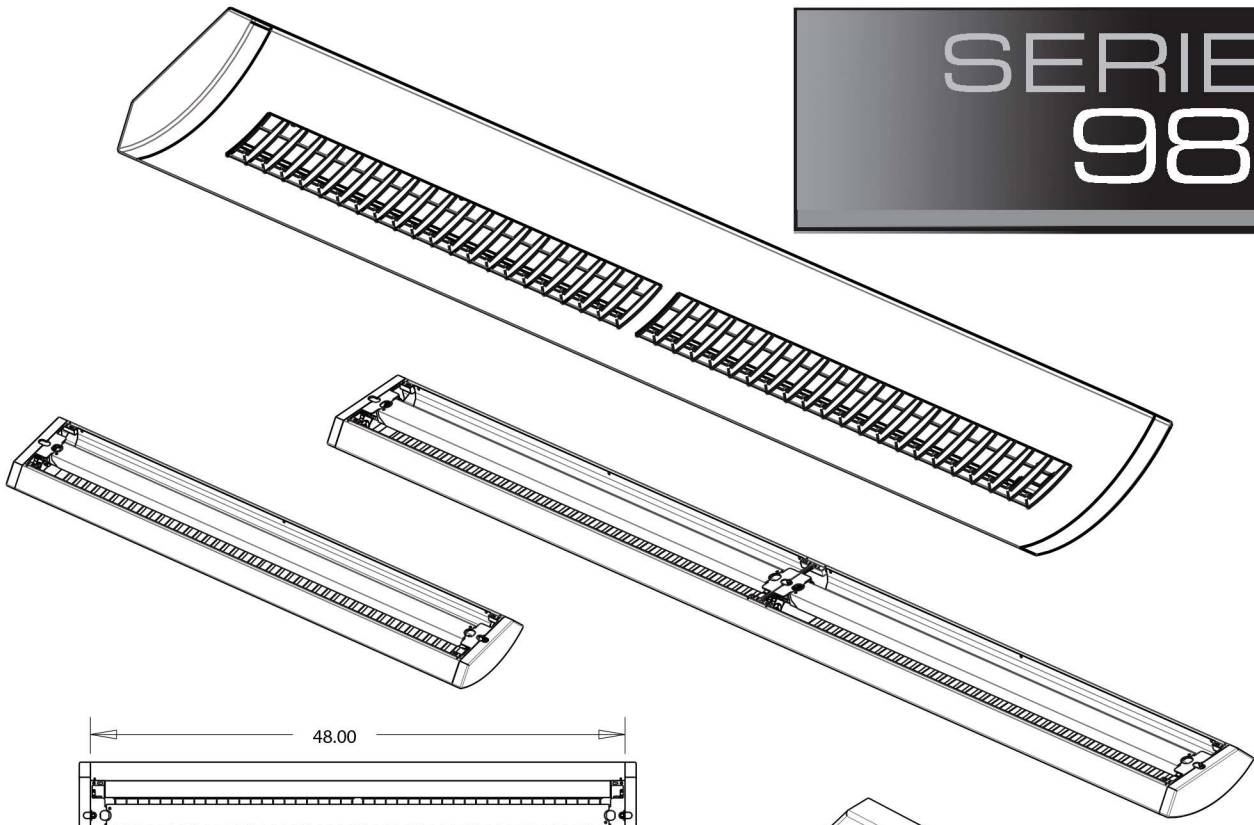

LED	
BOARDS	LENGTH
1-3	48"
2-6	96"

T8	
SIZE	LENGTH
(1-3) 32w	48"
(3-6) 32w	96"

Add 1" for each end cap

Rev 5-14-2020



Adam Metal Products Company • P.O. Box 450 • Ledgewood, NJ • 07852
 Phone: 973.770-1100 • Fax 973.770-1105 • www.adammetal.com





950 / 980 4ft ASSEMBLY

HARDWARE LIST (by others)

- (A) 8-32 X 1/4" Long Machine Screw (4 Pcs.)
- (B) 1/4 - 20 X 3/4" Long Allen Head Screw (4 Pcs.)
- (C) #8 X 1/4" Screw (6 Pcs.)

ASSEMBLY INSTRUCTIONS

- 1.) Mount End Cap to Body with (B)
- 2.) Insert Baffle Assembly (Snaps into 3" slots)
- 3.) Install both Side Reflectors with (C)
- 4.) Install Ballast Assembly with (A).

NOTE:

Peel off all protective coating on reflectors.

NOTE:

If running continuous string of bodies, connect bodies together with (B) to each Joiner. At the end of the run mount End Cap. Make sure each Joiner has a suspension system.

All suspension systems to be supplied by others.

Warning:

Each Joiner must have a suspension system.

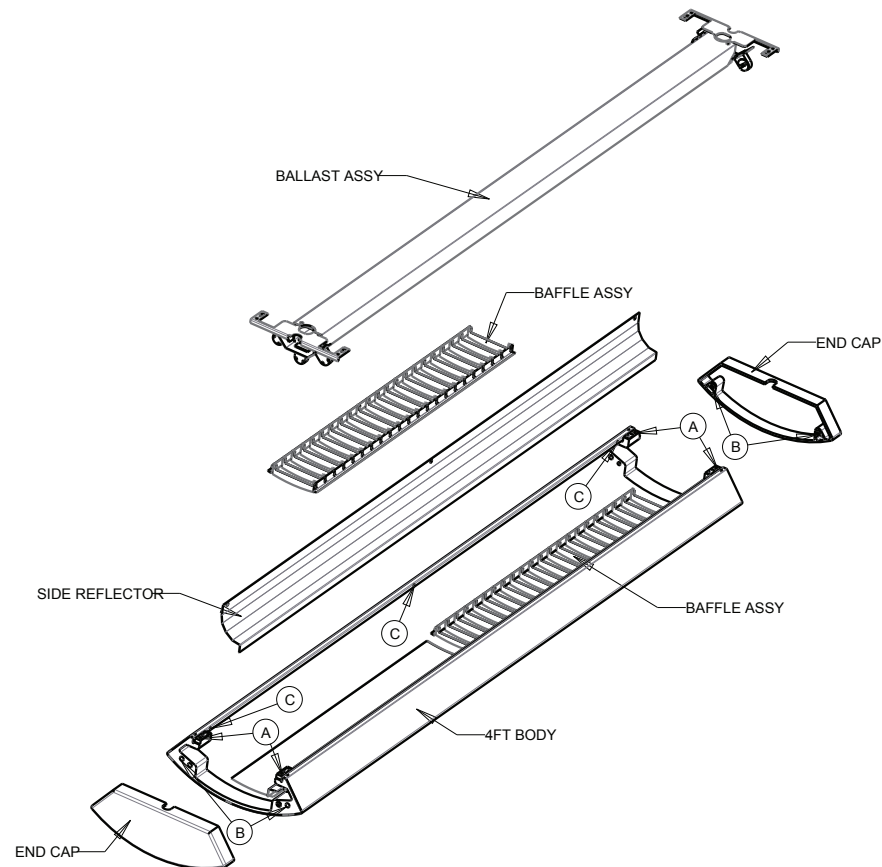

NOTE:

When attaching the Bodies together for continuous runs use the inside holes on the Joiner.





950 / 980 8ft ASSEMBLY

HARDWARE LIST (by others)

- (A) 8-32 X 1/4" Long Machine Screw (4 Pcs.)
- (B) 1/4 - 20 X 3/4" Long Allen Head Screw (4 Pcs.)
- (C) #8 X 1/4" Screw (6 Pcs.)

ASSEMBLY INSTRUCTIONS

- 1.) Mount End Cap to Body with (B)
- 2.) Insert Baffle Assembly (Snaps into 3" slots)
- 3.) Install Side Reflectors with (C)
- 4.) Install Ballast Assembly with (A).

NOTE:

Peel off all protective coating on reflectors.

NOTE:

If running continuous string of bodies, connect bodies together with (B) to each Joiner. At the end of the run mount End Cap. Make sure each Joiner has a suspension system.

All suspension systems to be supplied by others.

Warning:

Each Joiner must have a suspension system.

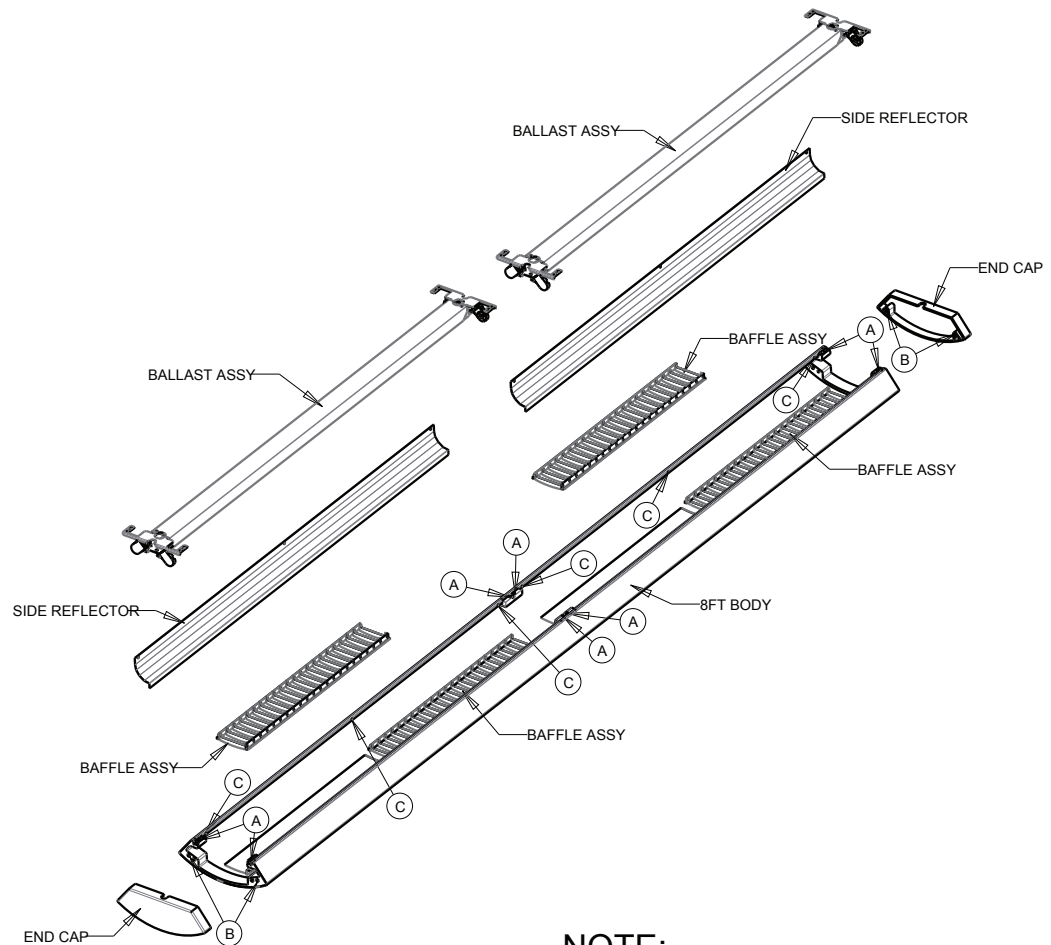

NOTE:

When attaching the Bodies together for continuous runs use the inside holes on the Joiner.





Adam Metal Products Company

Series 950 / 980 Center Slotted Linear Ballast Assembly Instructions

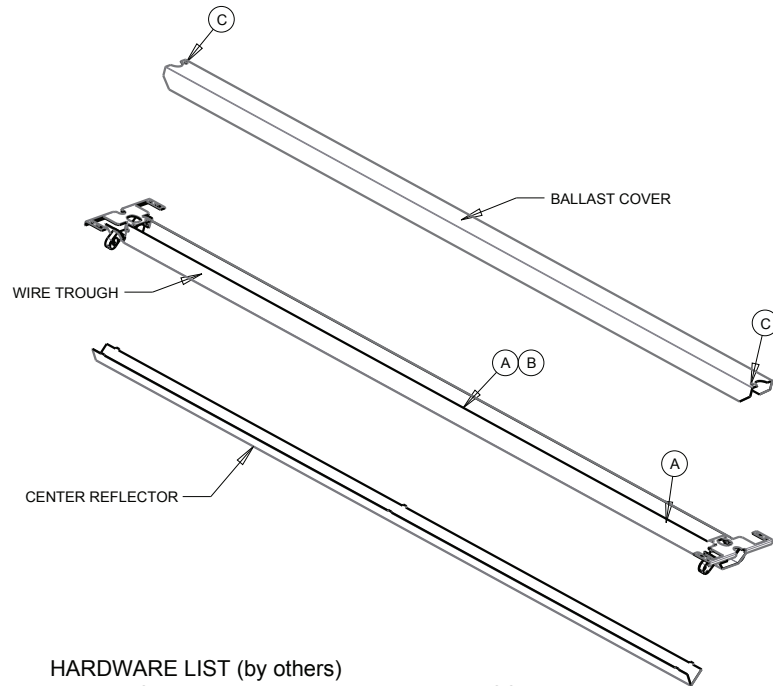

950 / 980 BALLAST ASSEMBLY

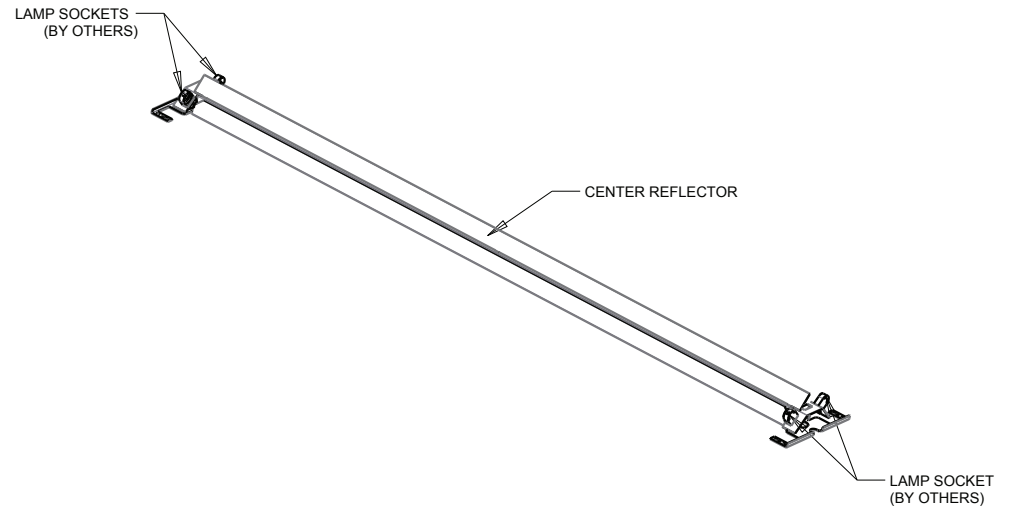

HARDWARE LIST (by others)

- (A) 8-32 Capped Washer Type Lock Nut (3 PCS)
(Palnut Company Cat.# D0832075)
- (B) 8-32 X 3/8" Long Screw
- (C) #8 X 1/4" Screw

RECOMMENDED SOCKETS

- 600V T5/G5
Vossloh Schwabe - 108660
Stucchi - 268
BJB - 26.620.2004.50
Etlin Daniels - FL622-L
- 600V T8
Vossloh Schwabe - 108331 (RH)
Vossloh Schwabe - 108328 (LH)

ASSEMBLY INSTRUCTIONS

- 1.) Attach Ballast to the 8-32 Stud provided in the Wire Trough with 8-32 Lock Nut (A).
- 2.) Attach other end of Ballast to the hole provided in the Wire Trough with 8-32 Screw & Lock Nut (A & B).
- 3.) Snap in Lamp Holders to the Bracket.
- 4.) Attach Ballast Cover to Wire Trough (C).
- 5.) Install Center Reflector to back of Trough using the tab and slots provided.

Note: If using 3 Lamps do not use Center Reflector.
3rd Lamp will replace Center Reflector down the center of the Trough.

**MADE IN THE
USA**

Adam Metal Products Company • P.O. Box 450 • Ledgewood, NJ • 07852
Phone: 973.770.1100 • Fax: 973.770.1105 • www.adammetal.com

